



HİDROLİK DİK GÖVDE TOMRUL BIÇKISI (ŞERİT) FM 120 - HDG



FİDANCILAR
AĞAÇ İŞLEME MAKİNELERİ



TEKNİK ÖZELLİKLER

Ana Motor : 45 kW / 60hp/1.400
Hidrolik Sistem Motor : 4 kW/1.400
Testere Gergisi : Hidrolik Sistem Pistonlu
Testere Ağızlık (Takozluk) Ayarı : Hidrolik Sistem Pistonlu

Volan Çap : 1.200 mm
Volan Genişlik : 140 mm
Kesme Yükseklik : Max. 1.100 mm
Kesme Genişlik : Max. 630 mm

Ağırlık : 4.800 kg
Şerit Boyu Max. : 120x1,2x9.300 mm
Şerit Boyu Min. : 80x1,0x8.900 mm
Boyutlar : 2.200x1.300x3.250 mm

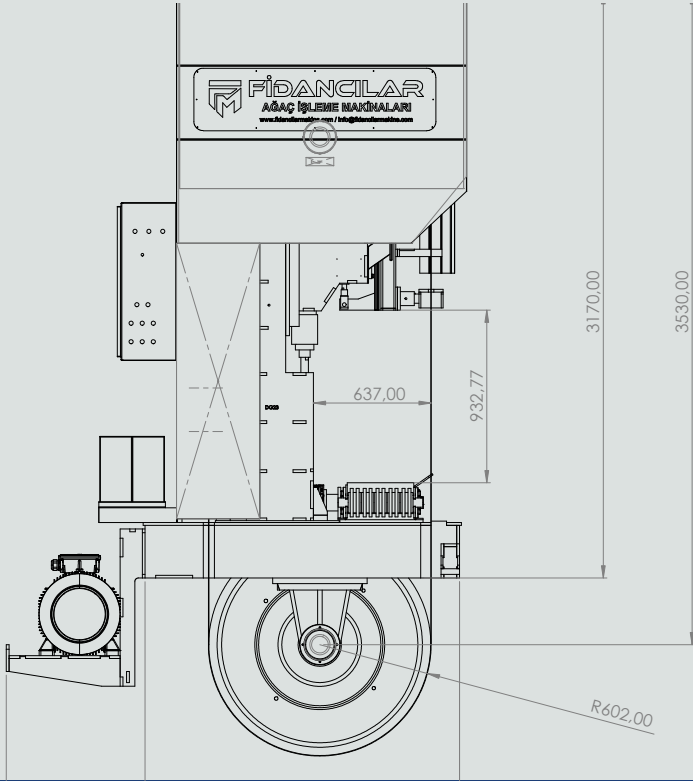

- ÇELİK ANA GÖVDE
- SERT DÖKÜM VOLANLAR
- MANUEL YAĞLAMA
- HİDROLİK GİRDİRME

- OTOMATİK MAZOTLAMA
- BURÇLU KAYIŞ KASNAK SİSTEMİ
- KOLAY KULLANIM KONTROL PANELİ
- ALT KASNAK SİYİRİCİ PNOMATİK SİSTEM

Yeşiltepe Mah. Uluyol Cad. No:41 Erenler/SAKARYA

+90 532 703 59 14

info@fidancilarmakine.com

www.fidancilarmakine.com

f @ /fidancilarmakine



**UZAKTAN KUMANDALI
KANCA HAREKETLİ TOMRUK ARABASI
FM 130 - UHKD - 4**



FİDANCILAR
AĞAÇ İŞLEME MAKİNELERİ

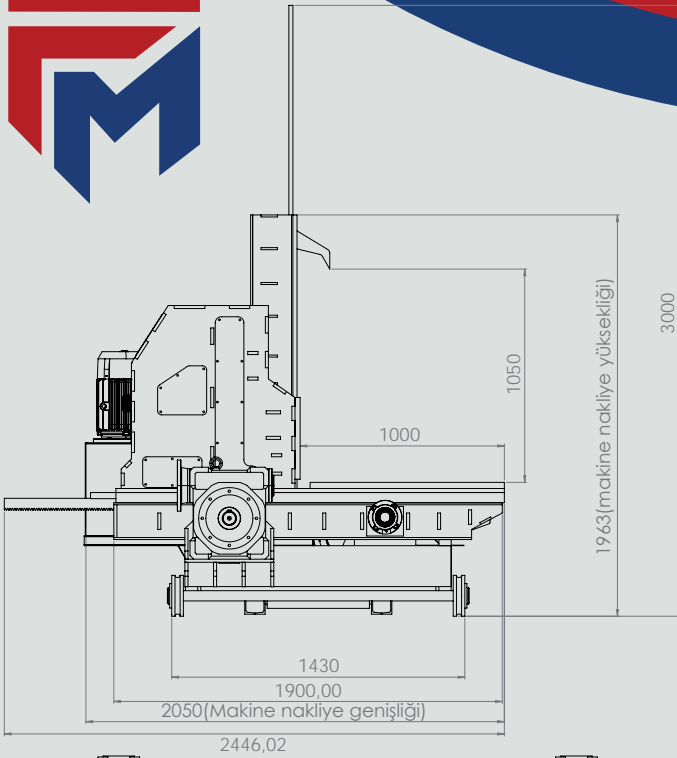

- TAM OTOMATİK
- HAREKETLİ KANCA
- OTOMATİK YAĞLAMA
- ERGONOMİK OPERATÖR KOLTUĞU
- UZAKTAN KUMANDALI JOYSTICK SİSTEM
- HIZLI VE KOLAY TOMRUK ÇEVİRME
- TOMRUK SABİTLEME SİSTEMİ
- GÜÇLÜ AĞIR GÖVDE
- PLC DOKUNMATİK EKLAN
- 11 kW HİDROLİK ÜNİTE MOTORU
- 18,5 kW YÜRÜYÜŞ ELEKTRİK MOTORU
- 7250 KG AĞIRLIK

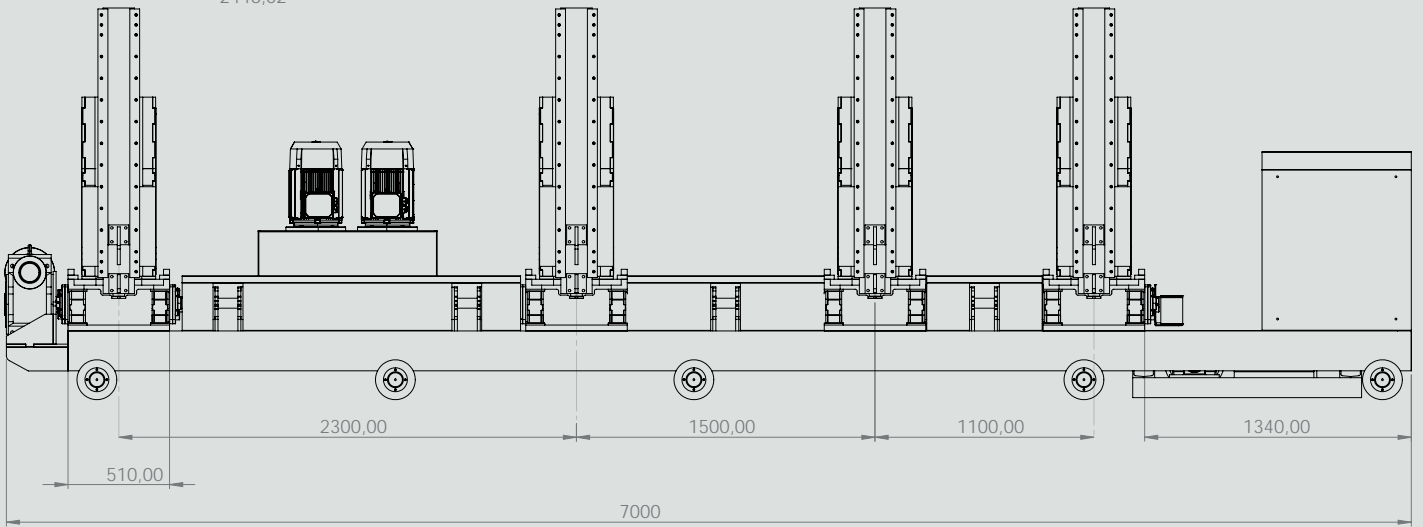

Yeşiltepe Mah. Uluyol Cad. No:41 Erenler/SAKARYA

+90 532 703 59 14

info@fidancilarmakine.com

www.fidancilarmakine.com

f @ /fidancilarmakine